

VISCOFLUX lite

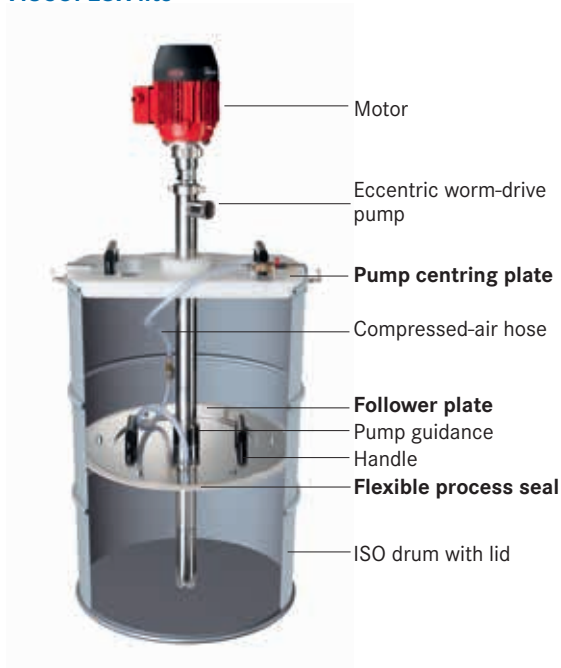

Advantages / Characteristics

- ▶ For transfer of higher-viscosity media which are just capable of flowing
- ▶ For drums with an inner diameter of 571.5 mm and sea container drums
- ▶ Less than 1 % residue in the drum
- ▶ Consisting of pump centring plate, follower plate with process seal
- ▶ Requires little space
- ▶ Mobile for easy transport to the drum
- ▶ Easy to assemble due to only a few components
- ▶ Follower plate for air-tight sealing of the medium
- ▶ For the use with FLUX eccentric worm-drive pumps
- ▶ Versions available for the use in hazardous areas zone 0/1



Technical data/version	VISCOFLUX lite	VISCOFLUX lite Ex
For drums	200 L, ISO drums	200 L, ISO drums, sea container drums
Dimensions	Inner Ø 571,5 mm	Inner Ø 571,5 mm, top Ø 540 mm, bottom Ø 571
Components	Pump centring plate, follower plate + process seal	
Ex-marking	-	II 1 G IIB TX
Air-connection	Quick coupling type 26 (6-8 bar)	
Materials		
Pump centring plate	PE	PE conductive
Handles	Duroplast FS 31	Stainless steel 316 Ti
Compressed-air hose	PVC	PA conductive
Follower plate	Stainless steel 1.4404/316 Ti (6 hole pattern)	Stainless steel 1.4404/316 Ti Pump guidance PE conductive (5 hole pattern)
Process seal	NBR white / NBR black / FKM black 6 hole pattern, LK 460 mm	FKM static dissipative, black NBR conductive, black EPDM conductive, black 5 hole pattern, LK 460 mm
Weight		
Pump centring plate	Approx. 6.5 kg	Approx. 7.5 kg
Follower plate with process seal	Approx. 13 kg	Approx. 13.6 kg
Eccentric worm-drive pumps		
Type	F 550 GS6/GS/S	F 550 GSX/SX
With outer diameter	54 mm	50 mm
Delivery rate max. (dependent on pump, motor, medium)	50 l/min	30 l/min
Immersion length	1000 mm	

Dimensions

VISCOFLUX lite

Dimensional drawings [mm]

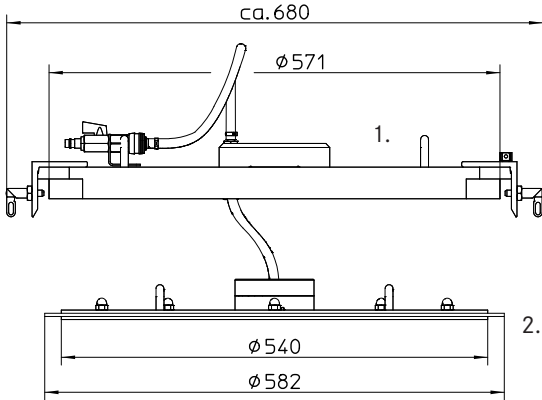

- 1. Pump centring plate
- 2. Follower plate with process seal
Ex version with equipotential bonding

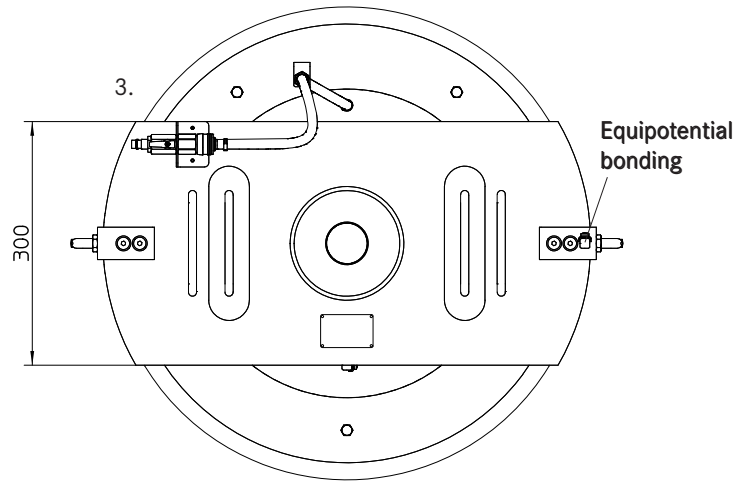

- 3. Pump centring plate
Ex version with equipotential bonding

System dimensions



Required room height for erection:
Approx. 2200 mm, without motor

VISCOFLUX lite Ex



System height assembled
(dependent on pump version and motor)

Part numbers

VISCOFLUX lite

VISCOFLUX lite

Description	Part no.
VISCOFLUX lite (Pump centring plate + follower plate)	10-001 22 310
Process seal NBR white	10-925 89 005
Process seal NBR black	10-925 89 006
Process seal FKM black	10-925 89 007

Recommended pumps for VISCOFLUX lite

Eccentric worm-drive pumps type F 550, **with outer diameter 54 mm**

in stainless steel, with G 1 ½ A discharge connection, open mechanical seal, seal material FKM, torsion shaft, immersion length 1000 mm (without hose connection, stator and stator housing)

Version	Description	Part no.
Version with planetary gear ratio 1 : 6.75	F 550 GS6-54/26 TW	10-550 23 301
Version with planetary gear ratio 1 : 15.9	F 550 GS-54/26 TW	10-550 25 676
Version with bearing flange	F 550 S-54/26 TW	10-550 25 652

Compatible stators

Version	Part no.
NBR black (incl. stator housing)	10-550 25 620
NBR white (incl. stator housing)	10-550 25 621
FKM black (incl. stator housing)	10-550 25 619

Compatible motors

For pump version	Description	Technical Data	Part no.
Version with planetary gear ratio 1 : 6.75	Three-phase motor F 403/2	0.55 kW, 2850 rpm	10-403 01 022
Version with planetary gear ratio 1 : 15.9	Commutator motor F 457	800 Watt, with low-volt protection	10-457 01 039
Version with bearing flange	Three-phase motor	0.75 kW, 930 rpm	10-001 03 392

Other pump versions, motors and accessories on request

Part numbers

VISCOFLUX lite Ex

VISCOFLUX lite Ex



Description	ISO drums	Sea container drums
	Part no.	Part no.
VISCOFLUX lite Ex (Pump centring plate + follower plate)	10-001 22 370	10-001 22 400
Process seal FKM static dissipative	10-925 89 048	10-925 89 054
Process seal NBR, conductive	10-925 89 049	10-925 89 055
Process seal EPDM, conductive	10-925 89 050	10-925 89 056
Process seal consists of	Process seal Ø 582 x 4 mm O-Ring Ø 50 x 4 mm	Process seal Ø 582 x 4 mm Process seal Ø 540 x 4 mm O-Ring Ø 50 x 4 mm

Recommended pumps for VISCOFLUX lite Ex

Eccentric worm-drive pumps type F 550, **with outer diameter 50 mm**

in stainless steel, with G 1 ½ A discharge connection, open mechanical seal, seal material FKM, torsion shaft, immersion length 1000 mm, incl. stator (PTFE black) and stator housing (without hose connection)

Version	Description	Ex-marking	Part no.
Version with planetary gear ratio 1 : 15.9	F 550 GSX-50/21 TW	II 1/2 G IIB T4	10-550 26 016
Version with bearing flange	F 550 SX-50/21 TW	II 1/2 G IIB T4	10-550 26 012

Compatible motors

For pump version	Description	Technical data	Ex-marking	Part no.
Version with planetary gear ratio 1 : 15.9	Commutator motor F 460-1 Ex	700 Watt, with low-volt protection	II 2 G Ex d e IIC T6 Gb	10-460 01 004
Version with bearing flange	Three-phase motor	0.8 kW, 930 rpm	II 2 G Ex e II T4	10-001 01 066

Necessary accessory

Description	Cable cross-section	Length	Part no.
Earth ground wire with grounding clamp in stainless steel (5 pieces are required for the whole system)	3 mm ²	4 m	10-931 90 023

Other pump versions, motors and accessories on request